



This manual is for reference and historical purposes, all rights reserved.

This page is copyright© by M. Butkus, NJ.

This page may not be sold or distributed without the expressed permission of the producer

I have no connection with any camera company

On-line camera manual library

This is the full text and images from the manual. This may take 3 full minutes for the PDF file to download.

If you find this manual useful, how about a donation of \$3 to: M. Butkus, 29 Lake Ave., High Bridge, NJ 08829-1701 and send your e-mail address so I can thank you. Most other places would charge you \$7.50 for a electronic copy or \$18.00 for a hard to read Xerox copy.

This will allow me to continue to buy new manuals and pay their shipping costs.

It'll make you feel better, won't it?

**If you use Pay Pal or wish to use your credit card,
click on the secure site on my main page.**



CONTAX Tix

Instruction manual • Bedienungsanleitung • Mode d'emploi • Manual de instrucciones

Thank you for purchasing this camera. Carrying on the Contax tradition of building cameras to the highest standards of photographic art and technology, this compact camera features a newly designed, high-performance F2.8 lens and matching high-speed, high-performance shutter, while adopting the revolutionary new Advanced Photo System (APS).

The use of standardized IX240 drop-in film cartridge lets you gain the full benefits of the Advanced Photo System while allowing enjoyable, easy picture-taking.

Before using your new camera, please be sure to read these Instruction manual fully to gain a thorough understanding of your new camera.

When Requesting Photofinishing Services



To receive the full advantages of the Advanced Photo System, be sure to have your film developed at a photolab displaying this mark. This mark is your assurance that the photolab facilities have been certified as complying with the technical requirements of the APS system.

Consult your photofinishing dealer for more details regarding the handling of Advanced Photo System film.

Print Quality Improvement (PQI) Function

Each time a picture is taken, the camera automatically records the frame's exposure information on the film in the form of magnetic data. This information is used to perform compensation during film processing to allow achievement of optimum print quality.

www.orphancameras.com

Contents

When Requesting Photofinishing Services	2	<3. Flash-In Mode>	
Names of Parts	10	<4. Flash-Off Mode>	
Viewfinder Display	14	<5. Landscape Mode>	
Display Panel	20	<Flash Distance Range>	
Quick Guide to Shooting	26	3. Selecting the Exposure Mode	98
[Basic Picture-Taking Procedures]		<1. Programmed AE>	
1. Load Battery	28	<2. Aperture-Priority AE>	
<When to Change the Battery>		4. Exposure Compensation	102
2. Set the Date and Time	34	<1. Single Frame Exposure Compensation Mode>	
3. Load a Film Cartridge	42	<2. Continuous Exposure Compensation Mode>	
4. Set the Main Switch to ON	54	5. Self-Timer Photography	114
5. Set the Aperture Ring to "P"	56	6. "Spot" Auto-Focus Photography	118
6. Compose the Subject and Shoot	58	<Focus-Lock/AE-Lock>	
7. Remove the Film Cartridge	64	7. Recording Exposure Data and Frame Titles	128
[Shooting Techniques]		Optional Accessories	136
1. Changing the Print Format	68	Camera Care	140
<C-Type, H-Type, P-type>		Specifications	148
2. Flash Photos	74		
<1. Auto-Flash Mode>			
<2. Red-Eye Reduction Auto-Flash Mode>			

Names of Parts

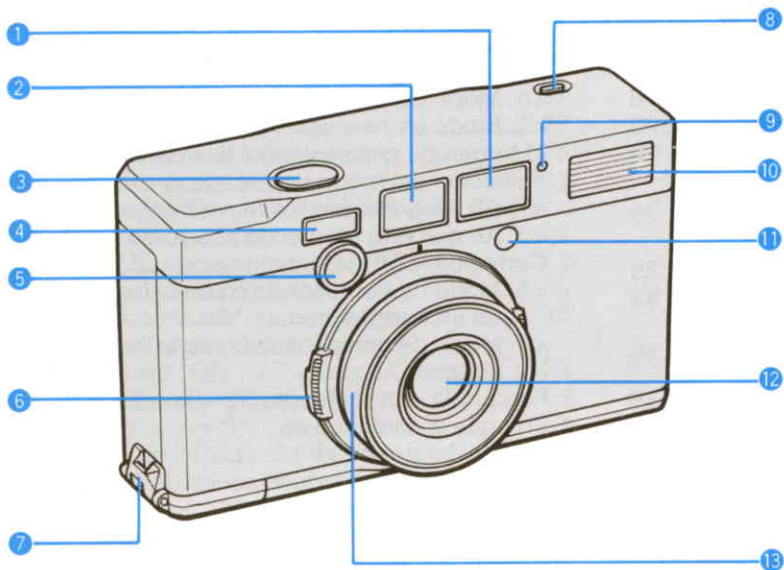

- 1 Viewfinder
- 2 Viewfinder Illumination Window
- 3 Shutter Release Button
- 4 Autofocus Window
- 5 AF Infrared Assist Beam Window
- 6 Aperture Ring
- 7 Strap Lug
- 8 Self-Timer Button
- 9 Self-Timer LED
- 10 Built-in Flash Unit
- 11 Light Sensor
- 12 Taking Lens and Lens Cover
- 13 Lens Hood

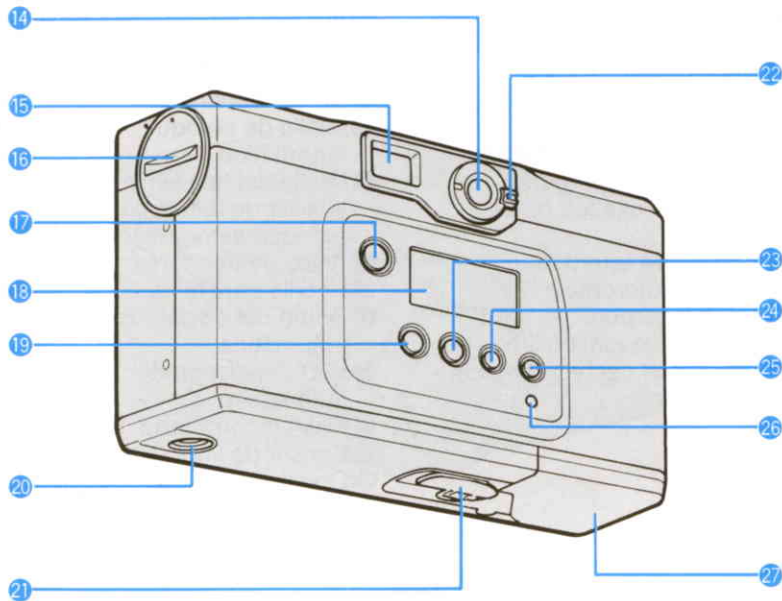

- 14 Main Switch**
 - Use to turn camera power ON/OFF.
- 15 Viewfinder Eyepiece**
- 16 Battery Compartment Cover**
- 17 Flash Mode Button**
- 18 Display Panel**
- 19 Exposure Compensation Button**
- 20 Tripod Socket**
- 21 Film Cartridge Compartment Cover Release Knob**
- 22 Print Format Selector**
 - Use to set the print aspect ratio (C, H, P).
- 23 Data Mode Button**
- 24 Data Select Button**
- 25 Data Set Button**
- 26 Manual Rewind Button**
 - Press this button to manually rewind a partially exposed roll of film.
- 27 Film Cartridge Compartment Cover**

Viewfinder Display

(Under low-light conditions, items ①~③ can be illuminated by depressing the shutter button halfway. Items ④~⑦ are displayed only when the camera is in focus with the shutter button depressed half-way.)

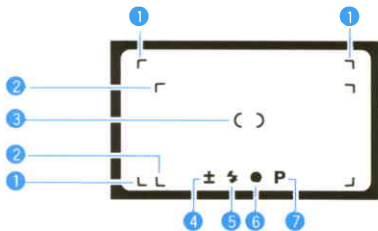

① Picture Area Frame

Under normal shooting conditions, the area visible within this frame will be recorded on film. The range of the picture area frame changes in accordance with the Print Format (print aspect ratio) setting.

② Close-range Parallax Frame

Place the subject within this frame when taking pictures at very close distances (approx. 0.35 m to 1.0 m).

③ Focusing Frame

The auto-focus mechanism operates based on the subject area visible within this frame.

④ Exposure Compensation Indicator

This indicator is displayed when exposure compensation has been set.

⑤ Flash Indicator

Indicator is on: camera is set for flash photography
Indicator flashes: flash is recharging
Indicator flashes quickly: current subject conditions are outside the effective range of the flash unit.

⑥ Focus Indicator (indicates focusing status)

Lighted: subject in focus
Flashing: focusing not possible

7 Program Indicator

Appears when aperture ring is set to "P" (Program AE). The indicator will also appear if the Aperture Priority AE mode has been selected, but current conditions exceed the exposure range of the mode; in this case, the camera automatically switches to the Program AE mode.

Flashing Indicator: Current light and subject conditions are outside the camera's automatic metering range. When the indicator flashes under bright conditions, overexposure will result; when the indicator flashes under dim conditions, underexposure will result.

(Bei schwachem Licht können die Anzeigen ①~③ beleuchtet werden, indem der Auslöser leicht gedrückt wird. Die Anzeigen ④~⑦ erscheinen nur, während auf das Motiv scharfgestellt ist und der Auslöser leicht eingedrückt gehalten wird.)

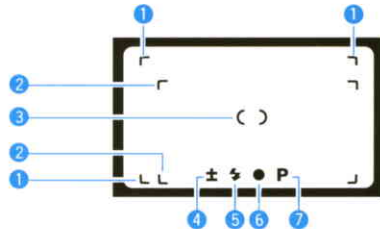

1 Bildbegrenzung

Bei normalen Aufnahmen begrenzt dieser Rahmen das Bildfeld. Er paßt sich automatisch dem eingestellten Bildformat (Bildseitenverhältnis) an.

Display Panel

(For purposes of explanation, the display panel is shown here with all information displayed; not all contents are displayed simultaneously under actual conditions of use.)

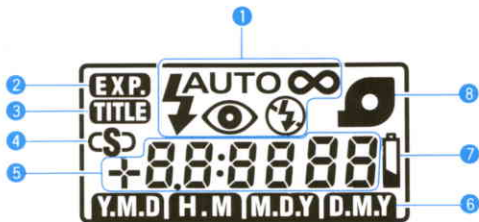

1 Flash Mode Indicator

Auto-flash mode: 

Red-eye reduction auto-flash mode: 

Flash-In mode: 

Flash-off mode: 

Landscape mode: 

2 Exposure Data Recording Indicator

3 Title Recording Indicator

4 Spot Auto Focus Indicator:

5 Exposure Compensation, Title Number, Language Number, Date, Shutter Speed (**), Exposure Counter.

6 Date Indicator

7 Battery Warning Indicator:

8 Film Cartridge Indicator:

* **Shutter Speed:** appears when shutter button is depressed halfway.

- When time exposure occurs under dark conditions, the elapsed exposure time is displayed when the shutter is pressed.
- A flashing "1000" indicates overexposure, and a flashing "15" indicates underexposure.

<About the Lens Hood>

- ① Rotate the hood in the direction of the arrow to remove.
 - ② Reverse the direction of the hood, and rotate clockwise onto the lens barrel to attach.
- Holding the lens hood lightly will facilitate smooth removal and attachment.
 - After using the hood, remove it and reattach it in its original position before storing the camera in its case.

<Hinweise zur Gegenlichtblende>

- ① Zum Entfernen der Gegenlichtblende drehen Sie sie in Pfeilrichtung.
 - ② Zum Gebrauch schrauben Sie die umgedrehte Gegenlichtblende im Uhrzeigersinn auf den Objektivtubus.
- Das Abnehmen und Anbringen der Gegenlichtblende läßt sich erleichtern, wenn sie ohne Kraftanwendung gehandhabt wird.
 - Entfernen Sie die Gegenlichtblende nach dem Gebrauch und bringen Sie sie wieder in ihrer Ausgangsstellung am Objektiv an, bevor Sie die Kamera im Etui unterbringen.

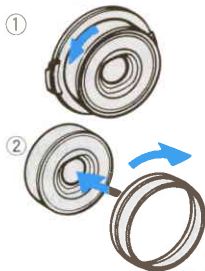

<A propos du pare-soleil>

- ① Tournez le pare-soleil dans le sens de la flèche pour le retirer.
 - ② Inversez le sens du pare-soleil et tournez celui-ci dans le sens des aiguilles sur le barillet de l'objectif pour le fixer.
- La mise en place et le retrait du pare-soleil sont facilités en le soutenant légèrement.
 - Après avoir utilisé le pare-soleil, retirez-le et replacez-le à sa position originale avant de ranger l'appareil photo dans son étui.

<Notas sobre la cubierta del objetivo>

- ① Gire la cubierta en la dirección de la flecha para sacarla.
 - ② Invierta la dirección de la cubierta y gírela hacia la derecha en el cilindro del objetivo para colocarla.
- Si se sostiene la cubierta del objetivo con seguridad, se facilitará la extracción y la colocación.
 - Después de utilizar la cubierta, extráigala y móntela en su posición original antes de guardar la cámara en su estuche.

<Attaching a Strap>

(Wrist strap and shoulder strap)

Attach the strap as shown in the illustration.

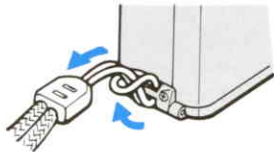

<Anbringen des Riemens>

(Tragschlaufe und Schultergurt)

Bringen Sie die Tragschlaufe wie in der Abbildung gezeigt an der Kamera an.

<Fixation de la courroie>

(pour dragonne et bandoulière)

Fixez la courroie comme indiqué sur l'illustration.

<Colocación de una correa>

(Correa para a muñeca y correa para el hombro)

Coloque la correa como se

muestra en la ilustración.

www.alpha.com

<Camera Case>

<Etui>

<Etui de l'appareil photo>

<Estuche de la cámara>

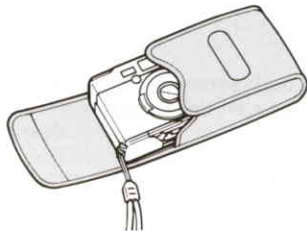

Quick Guide to Shooting

Kurz-Anleitung zum Fotografieren

1



Load battery (P. 28).
Einlegen der Batterie
(S. 29)
Mise en place de la pile
(P. 29)
Inserte la pila (P. 29).

2

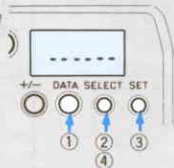

Set date and time
(P. 34).
Einstellung von Datum und Uhrzeit
(S. 35)
Réglage de la date et de l'heure
(P. 35)
Ajuste la fecha y la hora
(P. 35).

3

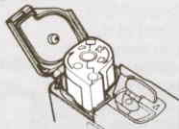

Insert a film cartridge
(P. 44).
**Einlegen der Film-
patrone** (S. 45)
**Insertion de la car-
touche de film** (P. 45)
Inserte el cartucho de película
(P. 45).

4

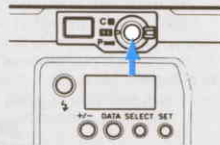

Set main switch to ON
(P. 54).
Einschalten der Kamera
(S. 55)
**Réglage du com-
mutateur principal**
sur "ON" (P. 55)
Ajuste el interruptor principal
en la posición ON
(P. 55).

Guide rapide pour la prise de vue

Guía rápida para fotografiar

5



Set aperture ring to "P"
(P. 56).

Einstellen des Blendenrings auf "P" (S. 57)

Réglage de la bague de diaphragme sur "P"
(P. 57).

Ajuste el anillo de aberturas a la posición "P" (P. 57).

6



Compose subject and press shutter release button (P. 58).

Wahl des Bildausschnitts und Auslösen (S. 59)

Composition de la photo et pression sur le déclencheur (P. 59).

Componga la imagen y dispare (P. 59).

7

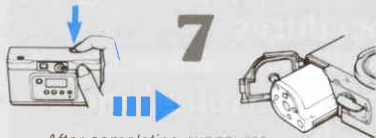

After completing exposures

Nach Belichten des Films

Quand toutes les vues sont prises

Después de terminar las exposiciones

Remove film cartridge
(P. 64).

**Entnehmen der Film-
patrone** (S. 65)

**Retrait de la cartouche
de film** (P. 65).

**Extraiga el cartucho de
película** (P. 65).

Basic Picture-Taking
Procedures

Normaler Aufnahme-
betrieb

Etapas fundamentales
de la prise de vue

Procedimientos básicos
para fotografiar

1. Load Battery

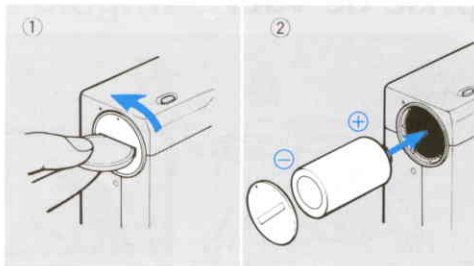

- 1 Use a coin or the strap adjuster to rotate the battery compartment cover in the direction of the arrow. Open the cover when the “•” mark on the cover is aligned with matching mark on the camera body.
- 2 Load a 3V lithium battery (CR2), aligning the polarities as noted inside the battery compartment. Replace the compartment cover and rotate to close.

<Battery Check>

After inserting a new battery, operate the camera once. The battery is operating properly if the battery warning indicator () does not appear.



<When to Change the Battery>

The battery should be changed if the battery warning indicator () appears in the display panel. Set the main switch to OFF, and load a new battery.



Load a new battery as soon as possible after removing an old battery from the camera.

If no battery is loaded within thirty seconds after removal of the old battery, the previously set date and time settings, as well as any frame titles, will be erased, and must be reset manually.

- Even if the battery warning indicator () lights, you can still take the pictures. But the battery should be replaced quickly. Once battery power drops below a rated limit, the display panel's battery warning indicator () will flash, and operation of the camera will no longer be possible.
- Some new batteries may experience an initial power drop when first loaded, resulting in the appearance of the battery warning indicator (). If the battery warning indicator appears immediately after loading a new battery, turn the main switch to OFF, and then ON again. If the battery warning indicator does not appear when the switch is ON again, it can be used safely.

2. Set the Date and Time

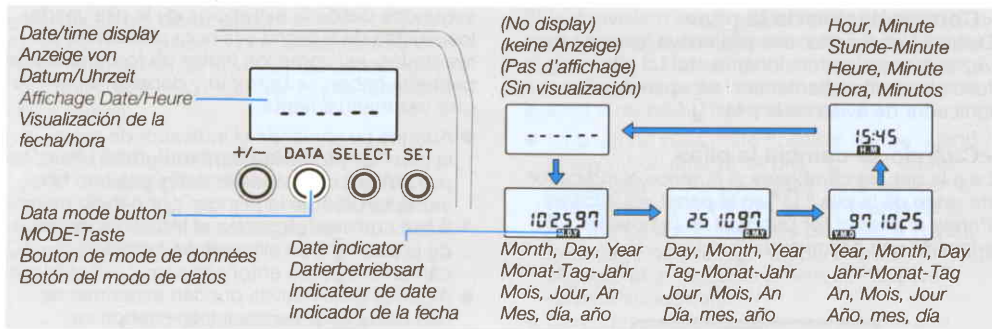

To set the date and time, press the main switch so that the camera power is set to **OFF**.

With the main switch OFF, press the Data Mode button so that the display panel shows either "-----" or the date and time.

- 1 Press the Data Mode button to select the item (date or time) you wish to set.

Each time the Data Mode button is pressed, the display will change in the following sequence: "-----" (no display) → Month/Day/Year → Day/Month/Year → Year/Month/Day → Hour/Minute

- 2 Press the Data Select button so that the digit you wish to change flashes.

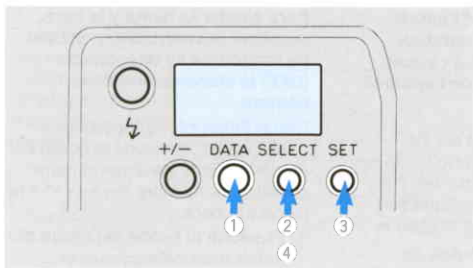

- 3 **Press the Data Set button to change the digit as desired.**

During setting of the time, the flashing colon “ : ” is provided to allow setting of seconds. Press the Data Set button with time signal to set the time most accurately.

- 4 **After setting both date and time, press the Data Select button until the numbers and “ : ” flashing will be stopped.**

- If the Data Select button is not pressed within about sixty seconds, the flashing display will change to the exposure counter, and whatever time and date values have been entered will be set automatically. Changing of time and date values must be performed while the numbers are flashing.

<To Record Time and Date On Film>

The time and date of each exposure can be recorded as magnetic data on the film, and used to allow printing of the time/date on both front and rear sides of the photo, or on the rear side only.

- ① **Set the camera's main switch to OFF.**
- ② **Press the Data Mode button and select the date and time information you wish to record.**

Each time the Data Mode button is pressed, the display will change in the following sequence:
"- - - - -" (no display) → Month/Day/Year →
Day/Month/Year → Year/Month/Day →
Hour/Minute

- About fifteen seconds after appearance of the date/time mode display, it will disappear and the display will return automatically to the date indicator. To confirm the contents you have set, press the Data Mode button once.

- ③ **When the main switch is set to ON and a photo is taken, the selected data will be recorded on the film.**

The font (size, design, and position of characters) used for printing information on photos may differ depending on the photofinishing service used. For details, ask at your photofinishing dealer.

3. Load a Film Cartridge

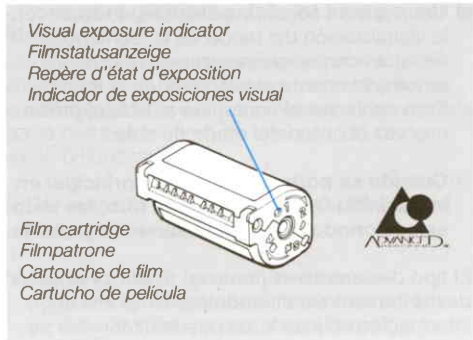

Use only film cartridges complying with the IX240 standard, and displaying the Advanced Photo System logo.

In the Advanced Photo System, film is completely enclosed in safe, convenient cartridges featuring easy drop-in loading. Information regarding film speed and the number of exposure frames is provided automatically to the camera.

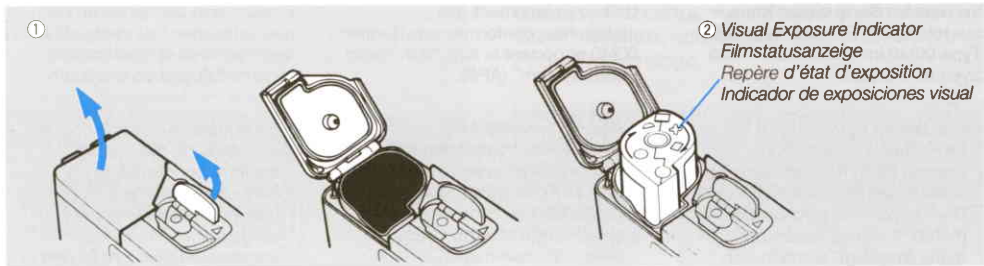

① **Open the cartridge compartment cover by moving the compartment cover release in the direction shown.**

② **Insert a new film cartridge with the visual exposure indicators visible on the upper end, as shown.**

- Confirm that the film cartridge's "O" (unused) indicator is showing.
- Avoid direct sunlight when loading or unloading film cartridges.

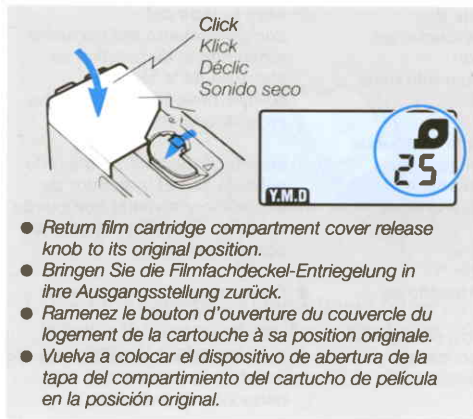

- ③ **Close the cartridge compartment cover so that it clicks securely into position.** When the film cartridge compartment is closed, the camera's motor automatically forwards the film. **You may take pictures as soon as the motor winding will be stops.**

The display panel will show the cartridge indicator “” and the “number of remaining frames” indicator.

- If “” indicator flashes, check to make sure the film cartridge is loaded properly.

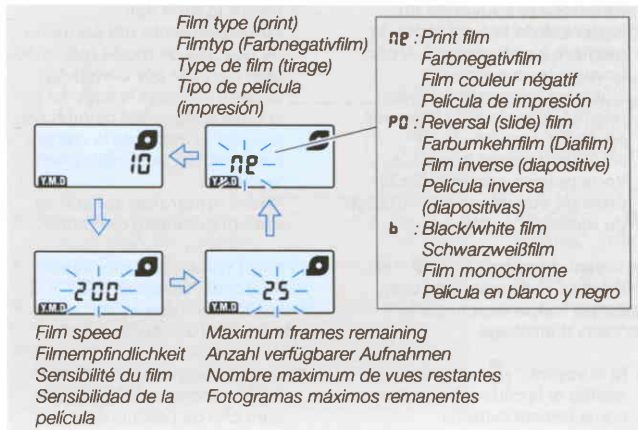

<Checking the film speed, maximum remaining frames, and film type>

With the main switch set to OFF, press the flash mode button; each time the button is pressed, the display panel will show flashing information in the following order: film speed → maximum remaining frames → film type.

After the display flashes about eight seconds, the display will return to the "remaining frames" display.

Visual Exposure Indicators/Filmstatusanzeigen/Repères d'état d'exposition/Indicadores de exposiciones visuales

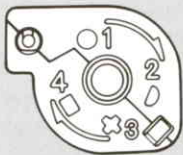

- Unused**
Unbelichtet
Non exposé
No utilizada
- Partly Exposed**
(not implemented on this camera)
Teilbelichtet *(Bei dieser Kamera wird die Markierung nicht angezeigt.)*
Partiellement exposé
(non utilisé avec cet appareil)
Parcialmente expuesta *(no implementada en esta cámara)*
- Fully Exposed (Unprocessed)**
Belichtet *(unentwickelt)*
Totalement exposé *(non développé)*
Completamente expuesta *(sin revelar)*
- Processed**
Entwickelt
Développé
Revelada

Visual Exposure Indicators

Advanced Photo System film cartridges are designed with visual exposure indicators on the upper end which display the status of the film inside the cartridge. On this camera, the following three exposure indicators are used: “Unused” (new film, no frames yet exposed), “Fully Exposed” (all frames have been exposed but not yet processed); and “Processed” (the film inside the cartridge has been fully exposed and processed).

- This camera is provided with a double-exposure prevention mechanism; as a result, a film cartridge whose "Fully Exposed" indicator ("☒") is showing cannot be reexposed if reloaded in the camera. In this case, the "FF" indicator will flash on the display panel.
- On this camera, if a film cartridge is removed midway through, the "Partly Exposed" indicator ("D") will not be set on the cartridge, even though not all frames have been exposed. Instead, the "Fully Exposed" indicator ("☒") will be set.
- Since this camera is not equipped with Mid-Roll Change (MRC) capability, the camera will not operate if a "Partially Exposed" cartridge of film (with "D" mark showing) is loaded in the camera; the roll of film will instead be set as "Fully Exposed" ("☒").
- Wird ein bereits belichteter, unentwickelter Film (die Filmstatusanzeige "☒" ist sichtbar) in die Kamera eingelegt, sind keine Aufnahmen möglich, und das Symbol "FF" blinkt im LCD-Monitor.
- Wird eine teilweise belichtete Filmpatrone aus dieser Kamera entnommen, erscheint die Markierung "Teilbelichtet" (D) nicht auf der Filmpatrone. Statt dessen wird die Markierung "Belichtet" (☒) angezeigt, obwohl der Film noch nicht vollständig belichtet ist.
- Wenn eine teilweise belichtete Filmpatrone eingelegt wird (die Markierung "D" ist sichtbar), können keine Aufnahmen mit dem betreffenden Film gemacht werden, da diese Kamera nicht über eine MRC-Einrichtung ("Mid-Roll Change") verfügt. Statt dessen wechselt die Markierung auf der Filmpatrone auf "Belichtet" (☒).

4. Set the Main Switch to ON

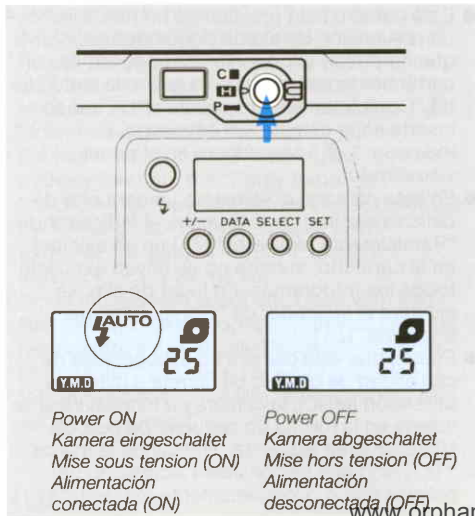

Press the main switch to turn the camera's power ON.

The lens cover will open, and the lens will move outward to the ready position.

The display panel will show the "⚡AUTO" indicator, showing that the auto-flash mode has been set.

- When the main switch is pressed once again, the lens retracts, the lens cover closes, and the camera power turns off.
- When you do not intend to use the camera again soon, be sure to set the main switch to OFF to prevent the shutter from being operated inadvertently.

5. Set the Aperture Ring to “P”

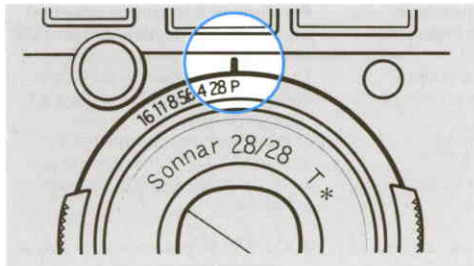

Rotate the aperture ring and set to the “P” position.

When the ring is set to the “P” position, the camera will be set to the Program AE (Auto-Exposure) mode; in this mode, lens aperture and shutter speed are controlled automatically in accordance with the brightness of the subject.

6. Compose the Subject and Shoot





- 1 **Looking through the viewfinder, point the focusing frame at the subject, and depress the shutter button halfway.**
When the camera has focused on that part of the subject within the focusing frame, the “●” indicator will light inside the viewfinder. The automatically selected shutter speed will appear on the display panel.
- 2 **Confirm that the “●” indicator has lighted, then gently depress the shutter farther until the shutter operates.**

This camera is equipped with an external passive-type multi-auto-focus system, allowing the camera to focus properly even when the subject is slightly outside the focusing frame.





When shooting under dim lighting conditions, the picture area frame, close-range parallax frame and the focusing frame will be illuminated when the shutter button is depressed halfway.

- Since the shutter speed may become slower during the flash-in mode “”, flash-off mode “” and the landscape mode “”, check the shutter speed on the display panel.
- Since the shutter will open for the indicated time duration, mount the camera on a tripod to avoid camera shake.



Bei schwachem Licht können Sie die Beleuchtung von Bildbegrenzung, Nahaufnahmen-Parallaxenbegrenzung und AF-Meßfeld durch leichtes Drücken des Auslösers einschalten.

- Überprüfen Sie die Anzeige der Verschußzeit im LCD-Monitor, da in den Betriebsarten “” (Blitz bei jeder Aufnahme), “” (Blitzabschaltung) und “” (Landschaft) u.U. eine längere Verschußzeit eingestellt wird.
- Um in einem solchen Fall ein Verwackeln der Aufnahme zu vermeiden, empfiehlt es sich, die Kamera auf einem Stativ zu befestigen.

- If the “⚡” indicator lights inside the viewfinder when the shutter button is depressed halfway, it means the flash will operate.
- When the shutter button is pressed, the camera's taking lens moves forward and back to effect focus; as a result, be sure not to touch or interfere with the taking lens when pressing the shutter.
- If the camera is unable to focus on the subject, the “●” indicator will flash in the viewfinder, and the shutter will not operate. In this case, use the focus lock function (p. 122) to focus on an alternate object at the same distance from the camera as the original subject, then turn the camera back toward the original subject to take the picture.
- When ambient conditions are too dark to allow accurate operation of the auto-focus mechanism, the AF infrared assist beam window emits infrared light to increase the accuracy of the auto-focus operation. The effective distance of the AF infrared assist beam is approx. 5 meters.

- Wenn das Blitzsymbol “⚡” bei leicht gedrücktem Auslöser im Sucher aufleuchtet, bedeutet dies, daß der Blitz zünden wird.
- Beim leichtem Drücken des Auslösers bewegt sich das Objektiv zur Scharfeinstellung vor und zurück. Bitte beachten Sie, daß die Fokussierbewegung des Objektivs nicht behindert werden darf.
- Wenn eine Scharfeinstellung nicht möglich ist, blinkt der Schärfenindikator “●” im Sucher, und der Verschuß ist gesperrt. In einem solchen Fall müssen Sie die Schärfenspeicherung (siehe S. 123) verwenden, um zunächst auf einen anderen Gegenstand scharfzustellen, der sich in etwa der gleichen Entfernung wie das Motiv vor der Kamera befindet, bevor Sie wieder den gewünschten Bildausschnitt wählen und auslösen.
- Wenn die herrschenden Lichtverhältnisse einen akkuraten Betrieb des Autofokus-Systems unmöglich machen, gibt das AF-Hilfslicht einen Infrarotstrahl ab, um die Genauigkeit der automatischen Fokussierung zu erhöhen. Die Reichweite des AF-Hilfslichts beträgt etwa 5 Meter.

7. Remove the Film Cartridge

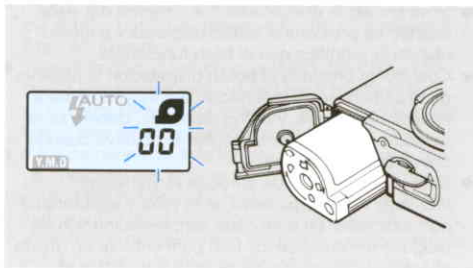

When all frames of film have been exposed, the film is automatically rewound into the cartridge.

During rewinding, the display panel's exposure counter will decrement until it reaches "0". When rewinding is completed, the motor will stop and the "  " indicator will flash.

Confirm that the motor has stopped and the "  " indicator is flashing, then open the film cartridge compartment cover and remove the exposed film cartridge.

- Have exposed film cartridges processed as soon as possible.
- If you wish to remove a film cartridge partway through exposure of the roll, use the pointed end of the accessory strap adjuster to press the manual rewind button "R". (Do not press the button with a needle or other sharply pointed object).
- Do not attempt to open the film cartridge compartment cover while the motor is still rewinding the film into the cartridge.
- If the cartridge compartment cover is inadvertently opened partway through a roll of film, immediately close it and manually rewind the film into the cartridge. In this case, it may be impossible to process any previously exposed frames due to exposure to outside light.
- Geben Sie den belichteten Film möglichst bald zur Entwicklung.
- Zum Rückspulen eines teilweise belichteten Films drücken Sie die Taste für vorzeitige Rückspulung "R" mit einem spitzen Gegenstand. (Verwenden Sie hierzu gegebenenfalls das Ende der Einstellflasche der Tragschlaufe, jedoch keine Nadel oder andere sehr spitze Gegenstände.)
- Versuchen Sie auf keinen Fall, das Filmfach zu öffnen, solange der Motor den Film noch hörbar zurückspult.
- Falls der Filmfachdeckel versehentlich geöffnet wurde, wenn der eingelegte Film erst teilweise belichtet wurde, schließen Sie den Deckel unverzüglich und spulen den Film manuell zurück. In einem solchen Fall kann es sein, daß Aufnahmen, die beim Öffnen des Deckels Licht ausgesetzt wurden, nicht entwickelt werden können.

1. Changing the Print Format

Shooting Techniques

Aufnahmetechniken

Techniques de prise de
vue

Técnicas fotográficas



*Print format selector
Bildformatschalter
Sélecteur de format de tirage
Selector del formato de
impresión*

As one feature of the Advanced Photo System, this camera allows you to choose between three print formats (print aspect ratios) by changing the position of the Print Format Selector.

In accordance with the format type selected, the viewfinder's picture area frame changes as shown; be sure to keep your subject within the indicated picture frame.

“C” (Classic) Type

This format produces the traditional 2:3 aspect ratio.

“H” (High-Definition) Type

This format produces a format with 9:16 aspect ratio.

“P” (Panorama) Type

With an aspect ratio of 1:3, this format produces a wide-type format suitable for broad landscapes. To produce the impression of the broadest possible space, it is recommended to stand back farther from the subject to include as much as possible in the frame.

- When using the “P” mode, the camera-subject distance should be at least one meter.

C-Format

Dies ist das “klassische” Bildformat mit einem Seitenverhältnis von 3:2.

H-Format

Bildformat mit einem Seitenverhältnis von 16:9 (“High-Definition”), das dem Bildfeld des menschlichen Auges Rechnung trägt.

P-Format

Panoramaformat mit einem Seitenverhältnis von 3:1, das sich für breite Landschaftsaufnahmen eignet. Mit zunehmender Aufnahmeentfernung wird der Panorama-Effekt stärker ausgeprägt, da ein größerer Bildausschnitt erfaßt werden kann.

- Bei Wahl des P-Formats sollte ein minimaler Abstand von 1 Meter zum Motiv eingehalten werden.

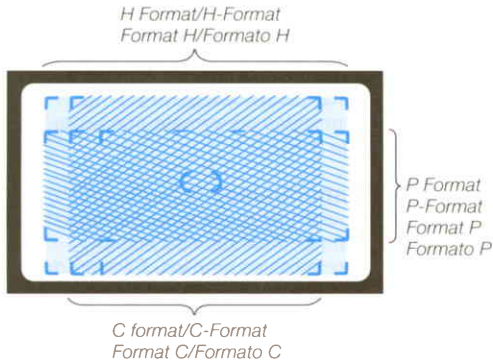

Three Print Formats

The three available print formats (C, H, and P) are produced in the following way. The “H” format is based on the actual full frame of picture. The “C” format is produced by cropping the right and left edges of the “H” format, while the “P” format is produced by cropping the top and bottom of the “H” format.

- Note that the actual angle of view does not change.
- The number of usable frames does not change, regardless of which print format is selected.

 : H Format/H-Format/Format H/Formato H

 : C Format/C-Format/Format C/Formato C

 : P Format/P-Format/Format P/Formato P

2. Flash Photos

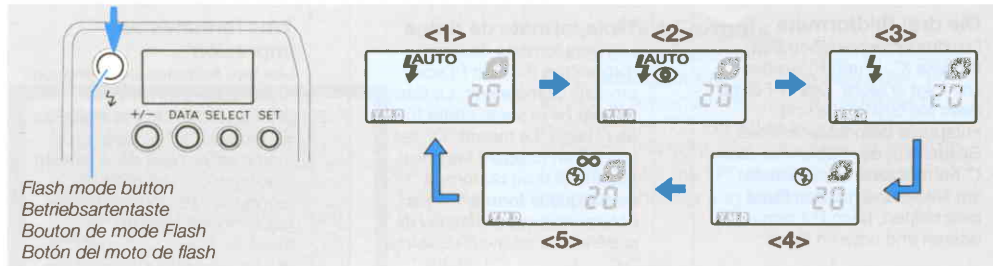

Each time the flash mode button “⚡” is pressed, the flash mode changes in the following sequence:

Auto-Flash Mode (the default mode set whenever the main switch is first turned on) → **Red-Eye Reduction Auto-Flash Mode** → **Flash-In Mode** → **Flash-Off Mode** → **Landscape Mode**

The selected mode is shown on the display panel. Use the mode best suited for your desired kind of photography.



- The default flash mode (the mode automatically set whenever the main switch is turned on) can be changed from the Auto-Flash Mode to another mode if desired. For details, see p. 94.

<1. Auto-Flash Mode> “ AUTO ”

In this mode, the camera's flash operates automatically whenever available lighting is so low as to result in a shutter speed slower than 1/60th second. (The shutter speed is fixed automatically at 1/60th second).

- When the flash is set to fire, the “ ” indicator lights inside the viewfinder.

[Auto-Flash Backlight Photography]



When the camera is set to either the Auto-Flash mode “ AUTO ” or Red-Eye Reduction Auto-Flash mode “  ”, if the central subject is standing in front of a strong source of light coming from behind (backlight), the flash may fire automatically to supplement the foreground lighting and allow the subject to be illuminated properly.

<1. Blitzautomatik> “ AUTO ”

In dieser Betriebsart schaltet die Kamera den Blitz automatisch zu, wenn das Umgebungslicht so schwach ist, daß die Aufnahme mit einer längeren Verschußzeit als 1/60 Sek. gemacht werden muß. (Die Verschußzeit wird automatisch fest auf 1/60 Sek. eingestellt.)

- Wenn der Blitz zündbereit ist, leuchtet das Symbol “ ” im Sucher auf.

[Gegenlichtaufnahmen mit Blitzautomatik]

Wenn die Kamera auf eine der Betriebsarten Blitzautomatik “ AUTO ” oder Reduzierung roter Augen “  ” eingestellt ist und sich eine starke Lichtquelle hinter dem Aufnahmegegenstand befindet (so daß dieser im Gegenlicht steht), wird der Blitz u.U. automatisch gezündet, um den Vordergrund aufzuhellen und für eine korrekte Belichtung zu sorgen.

<2. Red-Eye Reduction Auto-Flash

Mode> “ ”

When photographing human subjects with a flash in dark surroundings, the enlarged pupils of the subject's eyes may occasionally appear red (called “red-eye phenomenon”). To alleviate this phenomenon, the Red-Eye Reduction Auto-Flash mode causes the camera's flash to operate twice, each flash separated by an interval of about 0.7 second (the shutter operates only with the second flash). Since the pupils of the subject's eyes tend to close with the first flash, the potential for red-eye phenomenon is reduced at the second flash. The self-timer LED flashes between the first and second firing of the flash. Please be careful that neither the camera nor subject moves between the first and second flash operations.

- When set to this mode, the conditions for operation of the flash are the same as for the Auto-Flash mode (the flash operates automatically when available lighting is reduced).

<2. Reduzierung roter Augen> “ ”

Die Pupillen von Mensch und Tier öffnen sich bei schwachem Licht vollständig, so daß der rote Augenhintergrund im Bild sichtbar wird. Dieser Effekt kann mit dieser Funktion verringert werden, da der Blitz in einem Zeitintervall von ca. 0,7 Sekunden zweimal gezündet wird (die Verschlußauslösung erfolgt bei der zweiten Blitzzündung). Da sich die Pupillen beim Zünden des ersten Blitzes verengen, wird der sog. “Rotaugeneffekt” bei der zweiten Zündung reduziert.

Die Selbstauslöser-LED blinkt zwischen dem ersten und zweiten Zünden des Blitzes. Halten Sie die Kamera zwischen den zwei Zündungen betont ruhig, und weisen Sie auch Ihr Modell darauf hin, daß es sich während dieser Zeit nicht bewegen soll.

- In dieser Einstellung sind die Bedingungen der Blitzzündung die gleichen wie in der Blitzautomatik-Betriebsart (der Blitz wird bei schwachem Licht automatisch zugeschaltet).

<3. Flash-In Mode> “⚡”

In this mode, the flash operates with each shutter operation, regardless of ambient lighting conditions. Under brightly lighted conditions, this mode allows daylight fill-flash photography, and under dark conditions, “slow-synchro” photography.

[Daylight Fill-Flash Photography]

When photographing human subjects outdoors under certain lighting conditions, for example when the subject is located under bright direct sunlight or backlight, the subject will tend to be turned out dark. Under such conditions, using the flash-in mode will produce daylight fill flash, allowing both subject and background to be exposed naturally.

<3. Blitz bei jeder Aufnahme> “⚡”

In dieser Betriebsart zündet der Blitz ungeachtet der Lichtverhältnisse bei jeder Aufnahme. Damit eignet sie sich z.B. für Aufnahmen mit Tageslicht-Aufhellblitz und für Langzeit-synchronisation bei schwachem Licht.

[Aufnahmen mit Tageslicht-Aufhellblitz]

Bei Aufnahmen von Personen in einer hellen Umgebung, z.B. in direktem Sonnenlicht oder vor einem hellen Fenster, wird das Modell oft unterbelichtet. In derartigen Situationen empfiehlt sich der Gebrauch der Betriebsart “Blitz bei jeder Aufnahme” zur Erzeugung eines Tageslicht-Aufhellblitzes, der eine korrekte Belichtung von sowohl Motiv als auch Hintergrund ermöglicht.

["Slow-Synchro" Photography]

When photographing a human subject at night against a lighted skyline, sunset, or other feature you wish to also capture in the photograph, using the flash-in mode will produce "slow-synchro" photography. In this mode, the shutter speed will operate slowly, so as to capture the dimly lighted background scene, while the foreground subject will be properly illuminated by the camera's flash.

- Since the shutter speed may become quite slow during "slow-synchro" photography, use of a tripod is recommended to prevent camera shake.

[Langzeitsynchronisation]

Verwenden Sie die Betriebsart "Blitz bei jeder Aufnahme" beim Fotografieren bei schwachem Licht im Freien, z.B. für Porträtaufnahmen vor einem Sonnenuntergang, vor der Nachtsilhouette einer Stadt oder einem anderen wichtigen Hintergrund. In dieser Einstellung der Kamera werden Objekt und Hintergrund gleichermaßen einwandfrei belichtet, da eine für den Hintergrund geeignete längere Verschlusszeit eingestellt wird (Langzeitsynchronisation).

- Bei schwacher Allgemeinbeleuchtung kommt eine längere Verschlusszeit zur Anwendung, so daß es sich empfiehlt, die Kamera auf ein Stativ zu stellen, um Verwacklungsunschärfe zu vermeiden.

<4. Flash-Off Mode> “”

Use the Flash-Off mode to prevent the flash from operating when photographing a night skyline, sunset, or when you wish to capture the atmosphere of indoor ambient lighting. The exposure and shutter speed will be set automatically by the camera in accordance with the available light on the subject.

- Since the shutter speed may become quite slow when this mode is used at night, use of a tripod is recommended to prevent camera shake.
- In this mode, the “” indicator will not be displayed, even under dark conditions.

<4. Blitzabschaltung> “”

Diese Betriebsart eignet sich zum Einfangen stimmungsvoller Sonnenuntergänge oder Aufnahmen allein mit dem vorhandenen Licht. Das Objekt wirkt in der Aufnahme natürlich, da Blende und Verschußzeit je nach Helligkeit der Umgebung bestimmt werden.

- Da bei Verwendung dieser Betriebsart zu Nachtaufnahmen u.U. eine sehr lange Verschußzeit zur Anwendung kommt, empfiehlt es sich, die Kamera auf ein Stativ zu stellen, um Verwacklungsunschärfe zu vermeiden.
- In dieser Betriebsart leuchtet das Blitzsymbol “” (selbst bei sehr schwachem Licht) nicht auf.

<5. Landscape Mode> “∞”

Selecting this mode when photographing distant scenery will produce sharper landscape images.

- In this mode, the lens focus is fixed at infinity “∞” and the “●” indicator lights in the viewfinder, regardless of the proximity of any foreground subjects.
- In this mode, the camera automatically enters the “flash-off” mode; the flash will not fire even under dim lighting conditions.
- Since the shutter will be set at slower speeds when this mode is used under dim lighting conditions, use of a tripod is recommended to prevent camera shake.

<5. Landschaft> “∞”

Diese Betriebsart empfiehlt sich für Landschaftsaufnahmen oder Aufnahmen durch ein Glasfenster.

- In dieser Betriebsart wird das Objektiv ungeachtet des Abstands zum Objekt im Vordergrund mit der Entfernungseinstellung Unendlich scharfgestellt, und die Anzeige “●” leuchtet im Sucher auf.
- In dieser Betriebsart bleibt der Blitz (selbst bei schwachem Licht) abgeschaltet.
- Bei schwachem Licht ergeben sich Verschlusszeiten, die eventuell nicht mehr verwacklungsfrei aus der Hand gehalten werden können. Stellen Sie die Kamera deshalb gegebenenfalls auf ein Stativ.

■ When shooting under dim lighting conditions

The picture area frame, close-range parallax frame and the focusing frame will be illuminated when the shutter button is depressed halfway.

- Since the shutter speed may become slower during the flash-in mode “

■ Bei schwachem Licht

Durch leichtes Drücken des Auslösers wird die Beleuchtung von Bildbegrenzung, Nahaufnahmen-Parallaxenbegrenzung und AF-Meßfeld eingeschaltet.

- Überprüfen Sie die Anzeige der Verschußzeit im LCD-Monitor, da in den Betriebsarten “

88

■ Precautions during Flash Photography

- The viewfinder's "⚡" indicator flashes while the flash unit is charging, and lights steadily when charging is completed. Be sure to wait until the indicator lights steadily before taking your next flash picture.
- The "⚡" indicator is flashing quickly in the viewfinder means that the subject is outside the effective range of the flash unit. Using the flash under these conditions may result in an underexposed image. Either shoot at a wider lens aperture, or reduce the distance to your subject so that you are within the flash unit's effective range (see p. 92).
- The shutter will not operate while the flash unit is charging.

■ Vorsichtshinweise zu Blitzaufnahmen

- Das Blitzsymbol "⚡" blinkt im Sucher, während der Blitz auflädt, und wechselt nach beendetem Aufladen auf konstantes Leuchten. Warten Sie das Aufleuchten des Symbols ab, bevor Sie die nächste Aufnahme mit Blitz machen.
- Wenn das Blitzsymbol "⚡" in schnellem Tempo im Sucher blinkt, befindet sich das Objekt außerhalb des effektiven Blitzbereichs. Bei Blitzaufnahmen unter solchen Bedingungen besteht Unterbelichtungsgefahr. Wählen Sie daher entweder eine größere Blendeneinstellung, oder begeben Sie sich so nahe an das Hauptobjekt, daß die Blitzreichweite nicht überschritten wird (siehe S. 93).
- Während der Blitz auflädt, ist der Verschuß gesperrt.

<Flash Distance Range>

It is recommended to use the "P" (Program AE) mode when using flash photography, since the effective flash range will be shortened when small lens apertures are selected under the Aperture-Priority AE mode.

- The "⚡" indicator will flash inside the viewfinder when the subject is outside the effective range of the flash unit.
- When using slide film, the effective flash range will be even shorter than that indicated by the flashing indicator; shooting distances should be maintained within the ranges shown in the following table.

-  : ISO 400 film
 : ISO 200 film
 : ISO 100 film

F-stop Blendenwert Diaphragme Posición F	Flash Distance Range/Blitzreichweite/Plage des distances au flash/Margen de distancias del flash (m)					
	0.35	1	2	3	4	5
P						
F2.8						
F4						
F5.6						
F8						
F11						
F16						

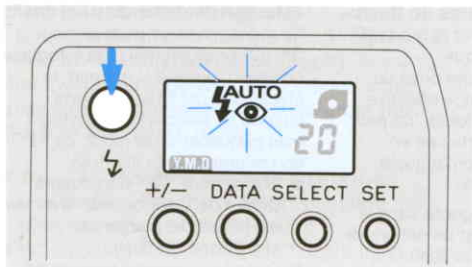

<Changing the Flash Mode>

The flash mode (the flash mode set whenever the main switch is first turned ON) can be changed if desired. You may find it convenient to change the flash mode to the one you use most frequently.

● **Note:** The landscape mode cannot be set.

- ① With the camera's main switch set to ON, hold the flash mode button depressed until the flash mode display begins flashing (approx. two seconds).

- ② When the display begins flashing, remove your finger from the button, and then press the button again to select the desired flash mode.
 - ③ In approx. eight seconds, the display will stop flashing and light steadily, then it will complete the setting.
 - The new setting will take effect when the shutter button is depressed halfway, or the main switch is set to OFF.
- ② Sobald die Anzeige blinkt, lassen Sie die Betriebsartentaste einmal los. Dann betätigen Sie die Taste erneut zur Wahl der gewünschten Blitzbetriebsart.
 - ③ Etwa acht Sekunden später wechselt die Anzeige der Blitzbetriebsart von Blinken auf konstantes Leuchten, um die neue Einstellung zu bestätigen.
 - Die neue Einstellung wird durch leichtes Drücken des Auslösers oder durch Abschaltung der Kamera wirksam gemacht.

3. Selecting the Exposure Mode 3. Wahl der Belichtungs-Betriebsart

3. Sélection du mode d'exposition 3. Selección del modo de exposición

The following exposure modes can be selected in accordance with the purpose and application of your photography. Rotate the aperture ring to select the mode.

Program AE (Auto-Exposure) Mode:

Set the aperture ring to "P".

Aperture-Priority AE Mode:

Set the aperture ring to the desired lens aperture (F2.8 - F16).



Selon le type de photographie et les effets souhaités, vous pouvez choisir un des modes d'exposition suivants. Faites tourner la bague de diaphragme pour sélectionner le mode.

Mode EA (exposition automatique) programmée: Réglez la bague de diaphragme sur "P".

Mode EA (exposition automatique) à priorité au diaphragme: Réglez la bague de diaphragme à l'ouverture (F2.8 - F16) souhaitée.

Je nach Aufnahmepurpose und -bedingungen können Sie zwischen den beiden Belichtungsautomatik-Betriebsarten wählen, indem Sie den Blendenring in die entsprechende Stellung drehen.

Programmautomatik:

Stellen Sie den Blendenring auf "P".

Blendenwahl:

Stellen Sie den gewünschten Blendenwert (2,8 - 16) mit dem Blendenring ein.

Pueden seleccionarse los siguientes modos de exposición de acuerdo con el propósito y aplicación fotográficos. Para seleccionar el modo, gire el anillo de aberturas.

Exposición automática (AE) programada:

Ajuste el anillo de aberturas a la posición "P".

Exposición automática (AE) con prioridad en la abertura:

Ajuste el anillo de aberturas a la abertura deseada del objetivo (F2,8 - F16).

<1. Program AE>

In this convenient mode, the camera automatically selects the optimum programmed aperture and shutter-speed combination in accordance with the subject's lighting conditions.

<2. Aperture-Priority AE>

In response to the lens aperture (f-stop) manually selected by the user, the camera automatically controls the shutter speed so as to produce the optimum exposure for the subject's lighting conditions.

This mode is most suitable when you wish to control the composition's depth of field in conjunction with a specific photographic purpose.

- If excessive subject illumination makes it impossible for the camera to produce proper exposure at the manually selected aperture, the camera will automatically switch to Program AE mode, and the "P" indicator will appear in the viewfinder.

<1. Programmautomatik>

In dieser praktischen Betriebsart stellt die Kamera je nach Helligkeit der Umgebung und Beleuchtung des Objekts automatisch die am besten geeignete vorprogrammierte Kombination von Blende und Verschußzeit ein.

<2. Blendenvorwahl (Zeitautomatik)>

Die Kamera wählt automatisch die am besten für die manuell eingestellte Blende geeignete Verschußzeit, damit das Objekt stets einwandfrei belichtet wird.

Diese Betriebsart empfiehlt sich vor allem dann, wenn Sie die Schärfentiefe für einen bestimmten Aufnahmepweck beeinflussen wollen.

- Wenn das Objekt so neu ist, daß mit der manuell gewählten Blende keine einwandfreie Belichtung erzielt werden kann, schaltet die Kamera automatisch auf Programmautomatik um, und der Buchstabe "P" leuchtet im Sucher auf.

<Relationship of Light Metering Range and Shutter Speed to Aperture in Each Exposure Mode (ISO 100)>

<Zusammenhang zwischen Belichtungsmeßbereich/Verschlußzeit und Blendenwert in jeder Belichtungs-Betriebsart (ISO 100)>

<Relation de la plage de posemètre et de la vitesse d'obturation par rapport au diaphragme en chaque mode d'exposition (ISO 100)>

<Relación del margen de medición de la iluminación y la velocidad del obturador con la abertura en cada modo de exposición (ISO 100)>

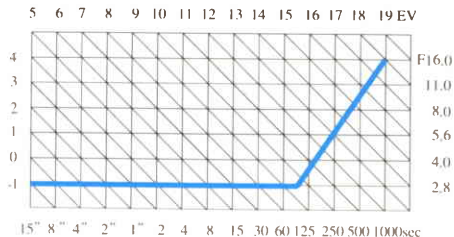

Program AE
 Programmautomatik
 EA programmé
 AE programada

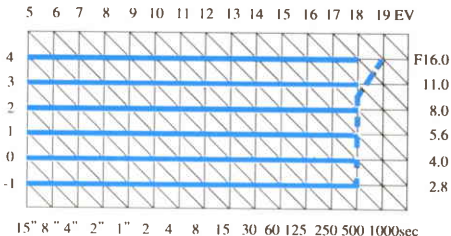

Aperture-Priority AE
 Blendenvorwahl
 EA à priorité au diaphragme
 AE con prioridad en la abertura

4. Exposure Compensation

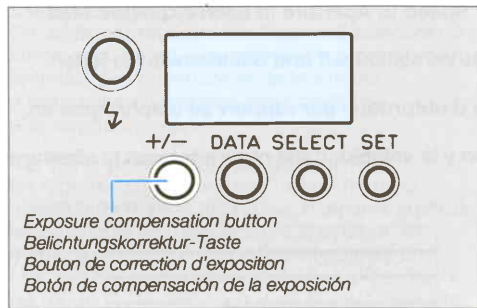

Exposure compensation is effective when photographing under conditions where excessive lighting contrast exists between the subject and its surroundings, making it likely that the subject will not receive proper exposure. Exposure compensation can also be used selectively to produce deliberately over- or underexposed images. Exposure compensation can be performed in either of the following ways:

- **Note:** During use of exposure compensation, the “±” indicator will appear in the viewfinder when the shutter button is depressed halfway.

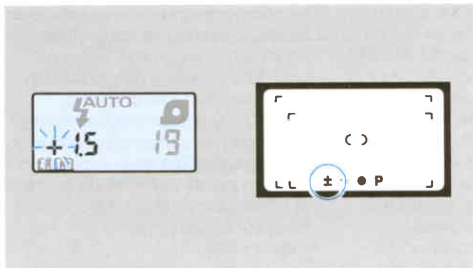

<1. Single Frame Exposure Compensation Mode>

This allows quick exposure compensation for a single frame.

When the Exposure Compensation button is pressed once, automatic exposure compensation of +1.5 EV will be added to the next frame exposed only.

- The display panel will show the “+1.5” indicator, with a flashing “+” indicator.
- If you wish to cancel the single frame exposure compensation mode before exposing the frame, press the Exposure Compensation button again.

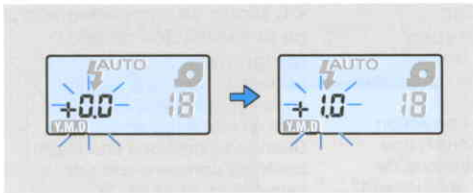

<2. Continuous Exposure Compensation Mode> (compensation range: +2 EV to -2 EV)

Use this mode when you wish to perform exposure compensation on several continuing frames, when using a lens filter that requires specific exposure compensation, or when you wish to deliberately over- or underexpose an entire roll of film.

- ① Hold the Exposure Compensation button depressed until the flashing “+0.0” display appears, then release the button.
- ② Press and release the Exposure Compensation button as necessary until the desired compensation value is displayed. Each time the button is pressed the displayed value changes in the following sequence (the displayed value will remain flashing in the display panel).

+0.0 → +0.3 → +0.7 → +1.0 → +1.3 → +1.7 →
 +2.0 → -0.0 → -0.3 → -0.7 → -1.0 → -1.3 →
 -1.7 → -2.0 → +0.0 (repeat)

*(Wiederholung der Sequenz)
 (et ainsi de suite)
 (repetición)*

③ Shoot as many frames as desired.

- Once the continuous exposure compensation mode is set, it will remain set until manually canceled.
- After completing use of the continuous exposure compensation mode, be sure to reset the mode so that the display panel shows no compensation value.
- To cancel the continuous exposure compensation mode, hold the Exposure Compensation button depressed until the exposure compensation display disappears (approx. 2 seconds when the camera's main switch is ON). The camera will then return to the single frame exposure compensation mode. Under normal conditions, it is recommended that the single frame exposure compensation mode be used in order to avoid mistakes caused by forgetting to reset the mode.
- Single frame exposure compensation cannot be used when the continuous exposure compensation mode is currently set.
- The exposure compensation display lights steadily when the camera's main power switch is set to OFF.

③ Machen Sie die gewünschte Anzahl von Aufnahmen mit Belichtungskorrektur.

- Nach Einstellung auf permanente Korrektur bleibt diese aktiviert, bis sie manuell aufgehoben wird.
- Achten Sie darauf, diese Betriebsart aufzuheben, nachdem Sie alle gewünschten Aufnahmen in dieser Betriebsart gemacht haben, so daß kein Korrekturwert im LCD-Monitor angezeigt wird.
- Um die permanente Belichtungskorrektur aufzuheben, halten Sie die Belichtungskorrektur-Taste bei eingeschalteter Kamera gedrückt, bis die Anzeige des Korrekturwerts vom LCD-Monitor verschwindet (nach ca. zwei Sekunden). Danach schaltet die Kamera in die Betriebsart Einzelbild-Belichtungskorrektur zurück. Diese sollte im Normalfall verwendet werden, um zu vermeiden, daß die Rückstellung der permanenten Belichtungskorrektur vergessen wird.
- Bei aktivierter permanenten Korrekturfunktion ist keine Belichtungskorrektur einer einzelnen Aufnahme möglich.
- Nach Abschaltung der Kamera leuchtet die Belichtungskorrekturanzeige konstant.



Compensation to the "+" side



No compensation



Compensation to the "-" side



<For Backlit Subjects>

Use exposure compensation of +0.3 to +2

When photographing objects against strong backlight, such as human subjects against a bright sky or ocean, beside a bright window, or otherwise when a bright background forms a substantial part of the image, the foreground human subject tends to be underexposed and may appear only as a darkened silhouette. In this case, compensate the exposure by a factor of +0.3 to +2 EV to increase the exposure given to the foreground subject.

<Against Darkened Backgrounds>

Use exposure compensation of -0.3 to -2

When photographing a spotlighted person against a darkened stage, or otherwise when a dark background forms a substantial part of the image, the foreground subject tends to be overexposed and washed out. To prevent this, compensate the exposure by a factor of -0.3 to -2 EV to decrease the exposure given to the foreground subject.

5. Self-Timer Photography



Use the self-timer mode for souvenir photographs and otherwise when you wish to include yourself in the photograph.

- 1 **Mount the camera on a tripod and compose the image.**
- 2 **Point the focusing frame at the subject and press the self-timer button.**

- 3 **The lens will focus, and the self-timer operation will begin.**

The viewfinder's "●" indicator and the self-timer LED on the front of the camera will begin flashing, and ten seconds later, the shutter will operate. During operation of the self-timer, the display panel will show the remaining number of seconds until exposure.

- Focus and exposure are automatically locked at the time the self-timer begins operation.
- The self-timer will not operate if the flash is currently charging (during selection of flash photography).
- To cancel the self-timer after it has begun operating, press the self-timer button again, or set the Main Switch to OFF.
- If the self-timer does not begin operating, and the “●” indicator flashes when the self-timer button is pressed, it means the focusing frame has been aimed at an object which the camera is unable to focus on. In this case, recompose the image so that the focusing frame is pointed at a different part of the subject, and press the self-timer button again.
- Schärfe und Belichtung werden beim Start des Selbstauslösers gespeichert.
- Während der Blitz auflädt (bei Gebrauch einer Blitzbetriebsart), steht der Selbstauslöser nicht zur Verfügung.
- Zur Abschaltung des bereits laufenden Selbstauslösers drücken Sie die Selbstauslösertaste erneut oder schalten den Hauptschalter aus.
- Wenn der Selbstauslöser nicht startet oder die Anzeige “●” nach Drücken der Selbstauslösertaste blinkt, bedeutet dies, daß das AF-Meßfeld auf ein Objekt gerichtet ist, auf das nicht scharfgestellt werden kann. In einem solchen Fall wählen Sie den Bildausschnitt so, daß das AF-Meßfeld auf ein anderes Motivdetail gerichtet ist, bevor Sie die Selbstauslösertaste erneut drücken.

6. "Spot" Auto-Focus Photography

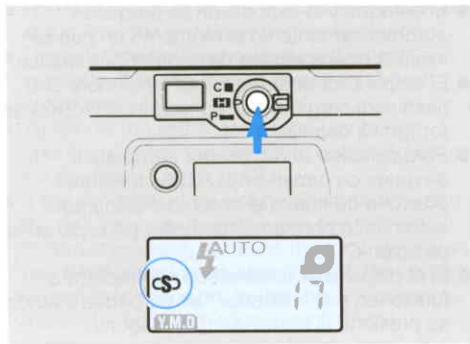

When you wish to focus the camera on a specific part of the subject, use the "spot" auto-focus mode. The camera's focus will then be set on that small part of the subject visible only in the center portion of the focusing frame.

- ① **Set the camera's main switch to OFF.**

- ② **Hold the main switch depressed until the “CS” indicator appears in the display panel (approx. two seconds).**

Confirm that the “CS” indicator is showing, then release your finger from the main switch. The camera power turns ON with the focusing method now changed to the “spot” auto-focus mode.

Other functions of the camera continue to operate the same as before.

- The “spot” auto-focus mode is canceled when the main switch is set to OFF.
- The focusing mode cannot be changed while the camera’s main switch is set to ON.

- ② **Halten Sie den Hauptschalter gedrückt, bis die Anzeige “CS” im LCD-Monitor erscheint (nach ca. zwei Sekunden).**

Nachdem Sie sich vergewissert haben, daß die Anzeige “CS” leuchtet, nehmen Sie den Finger vom Hauptschalter. Die Kamera schaltet sich in der Betriebsart “Spot”-Autofokus ein.

Alle übrigen Funktionen der Kamera arbeiten auf normale Weise.

- Durch Abschaltung der Kamera wird die Funktion “Spot”-Autofokus aufgehoben.
- Bei eingeschalteter Kamera kann die Fokussierbetriebsart nicht geändert werden.



①



②



<Focus Lock/AE Lock>

In this mode, the camera locks the focus and exposure values set when the shutter button is depressed halfway. This function is convenient when photographing scenes in which the main subject lies far outside the focusing frame.

- ① **Point the focusing frame at that specific part of the scene on which you wish the camera to focus, and depress the shutter halfway.**

The camera will focus and the “●” indicator will light inside the viewfinder, indicating that the focus and exposure are locked.

② **While holding the shutter button depressed halfway, move the camera's viewfinder to compose the picture as originally desired; when the scene is composed, press the shutter fully so that the shutter operates.**

- Focus lock and AE lock will be maintained so long as the shutter button is held halfway depressed; as a result, the focus and exposure settings will not change even if the camera direction is changed to point at a different subject.
- Focus lock and AE lock are canceled by releasing your finger from the shutter button.

② **Halten Sie den Auslöser leicht gedrückt und schwenken Sie auf den endgültigen Bildausschnitt. Drücken Sie den Auslöser zur Belichtung dann voll durch.**

- Solange der Auslöser angetippt gehalten wird, bleiben Scharf- und Belichtungseinstellung gespeichert, so daß der Ausschnitt nach Wunsch verändert werden kann.
- Die Speicherung wird gelöscht, sobald Sie den Auslöser freigeben.

<Difficult-to-Focus Subjects>

The camera's auto-focus mechanism may not be able to focus properly on the following kinds of subjects. In such cases, use the focus-lock feature to lock the camera's focus on another object located at an equivalent distance from the camera as the desired subject, then return the camera to the original position and take the picture.

- *Subjects with very low contrast.*
- *Subjects characterized by a recurring pattern.*
- *Very dark subjects.*
- *Subjects composed primarily of horizontal stripes.*
- *Extremely bright or glossy subjects.*
- *Scenes in which a bright light source is located inside or very near the focusing frame, or when the sun or other bright light source is visible inside the viewfinder.*
- *Scenes in which two objects visible inside the focusing frame are located at greatly differing distances.*
- *Quickly moving subjects.*

<Autofokus-Grenzfälle>

In den nachstehend geschilderten Fällen kann die automatische Scharfeinstellung Schwierigkeiten bereiten. Fokussieren Sie dann auf ein Ersatzobjekt in gleicher Entfernung und verfahren Sie wie unter "Schärfenspeicherung" beschrieben.

- *Bei extrem kontrastarmen Objekten.*
- *Bei Objekten mit regelmäßigen geometrischen Mustern.*
- *Bei sehr dunklen Objekten.*
- *Bei Objekten, die hauptsächlich aus waagerechten Linien bzw. Streifen bestehen.*
- *Bei extrem hellen oder glänzenden Objekten.*
- *Bei Aufnahmen, in denen sich eine starke Lichtquelle in bzw. in der Nähe des AF-Meßfelds befindet, oder wenn die Sonne oder eine andere starke Lichtquelle im Sucher sichtbar ist.*
- *Bei Aufnahmen, in denen sich zwei Objekte in großer Entfernung voneinander gleichzeitig im AF-Meßfeld befinden.*
- *Bei Objekten, die sich schnell bewegen.*

7. Recording Exposure Data and Frame Titles



When any of the following data items are displayed on the display panel, the data will be recorded on the film in the form of magnetic data, and can be printed on the rear of photographic prints.

- 1 **Exposure data** (F-stop, shutter speed, exposure compensation value) (In this mode, the indicated data will be recorded on all frames.)
- 2 **Single-frame title** (In this mode the recording mode reverts to the "no data" mode ④ after shooting one frame.)
- 3 **Continuous title** (When this mode is set, the selected title is recorded on all frames.)
- 4 **No data**

Example of rear-surface printing
Beispiel der Einbelichtung auf der Rückseite des Abzugs
Exemple d'impression au verso
Ejemplo de impresión en la superficie posterior

Exposure data
Belichtungsdaten
Données d'exposition
Datos de exposición

F-stop
Blendenwert
Diaphragme
Número F

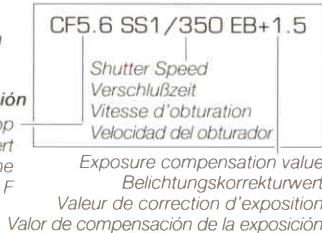

Frame title
Bildtitel
Titre de vue
Título de fotograma



* Title data can be selected from nine titles in six languages (total fifty-four), including such sentiments as "Congratulations" and "I Love You." For details, see p. 135.

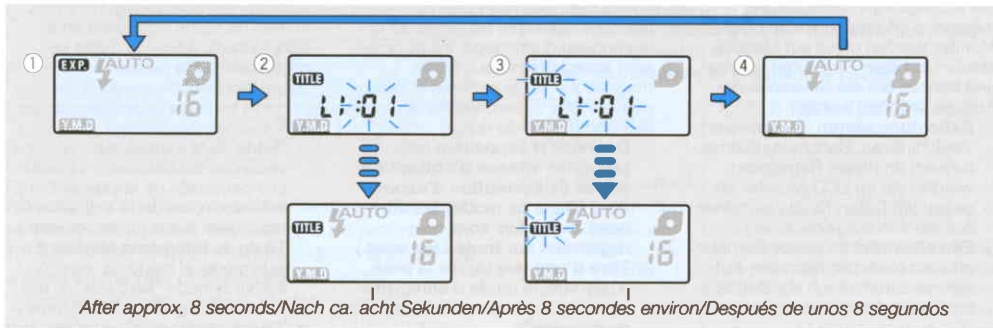

1. Selecting Data to Record

With the camera's main switch set to ON, press the Data Mode button. Each time the button is pressed, the recording data will change in the following sequence:

- ① Exposure Data → ② Single-Frame Title → ③ Continuous Title → ④ No Data → ① → (repeat)

Select the desired data. (When ② or ③ is selected, after approx. 8 seconds, the display will automatically switch from the title/language number display and return to the exposure counter.)

- The selected title/language numbers can be confirmed by pressing the Data Select button.

Title number/Titelnummer/Numéro de titre/Número de título



Language number
Sprachnummer
Numéro de langue
Número de idioma

2. Selecting a Title

Select a title and language from the chart on p. 135, and set the corresponding language and title numbers.

<Setting Language and Title Numbers>

- 1 Press the Data Mode button so that the recording data display is set either to “single-frame title” or “continuous title”.
- 2 Press the Data Select button; each time the button is pressed, the flashing display will switch alternately between “title number” and “language number.”

- ③ Press the Data Set button to set the flashing display to the title or language number desired.
- ④ Approx. eight seconds after setting the title number and language number, the display will return automatically to the exposure counter.

- ③ Drücken Sie die SET-Taste, um die blinkende Anzeige auf die jeweils gewünschte Nummer einzustellen.
- ④ Etwa acht Sekunden nach Einstellung der Titelnummer und Sprachnummer kehrt der Bildzähler automatisch in den LCD-Monitor zurück.

- ③ Appuyez sur le bouton de réglage des données pour régler l'affichage clignotant au numéro de titre ou de langue souhaité.
- ④ Environ 8 secondes après le réglage du numéro de titre ou de langue, l'affichage repasse automatiquement au compteur de vues.

- ③ Presione el botón de ajuste de datos para ajustar la visualización parpadeando al número de título o idioma deseado.
- ④ Unos ocho segundos después de haber ajustado el número de título y el número de idioma, la visualización retornará automáticamente a la del contador de exposiciones.

Title and Language Chart/Verfügbare Titel und Sprachen
 Tableau des titres et des langues/Gráfica de títulos e idiomas

Title number Titelnummer Numéro de titre Número de título	Language number/Sprachennummer/Numéro de langue/Número de idioma					
	L1 Japanese	L2 English	L3 Deutsch	L4 Français	L5 Español	L6 Italiano
01	オメデトウ	Congratulations	Herzliche Glückwünsche	Félicitations	Felicidades	Congratulazioni
02	アリガトウ	Thank You	Dankeschön	Merci	Gracias	Grazie
03	アイラブユー	I Love You	Ich liebe Dich	Je t'aime	Te quiero	Ti amo
04	パーティ	Party	Party	Réception	Fiesta	Festa
05	タンジョウビ	Birthday	Geburtstag	Anniversaire	Cumpleaños	Compleanno
06	ケッコン	Wedding	Hochzeit	Mariage	Boda	Matrimonio
07	メリー クリスマス	Merry Christmas	Fröhliche Weihnachten	Jeux Noël	Feliz Navidad	Buon Natale
08	アケマシテ オメデトウ	Happy New year	Frohes Neues Jahr	Bonne Année	Feliz Año Nuevo	Felice Anno Nuovo
09	ソツギョウ	Graduation	Abschlußfeier	Remise des Diplômes	Graduación	Laurea

Optional Accessories

<Contax Tix 30.5 Lens Ring>

This lens ring is necessary in order to attach 30.5mm filters or a Tvs metal lens hood to the camera lens. (The accessory lens hood is removed and the 30.5 mm ring is attached).

<Contax 30.5mm filter (screw-type)>

Available in five types: P (lens protector), 1A, L39 (UV), A2 (81B), B2 (82A).

<Contax Tvs metal hood>

Can be used together with one 30.5 mm filter. Attaches with 30.5 mm screw-type ring.

<Contax Tvs metal cap K-34 (cover type)>

Attaches by fitting over the Tvs metal hood.

<Lens Cap K-31>

Attaches to a Contax 30.5 mm filter.

Sonderzubehör

<Contax Tix 30,5-mm-Adapterring>

Dieser Adapterring wird zum Anbringen eines 30,5-mm-Filters oder einer Contax Tvs Metall-Gegenlichtblende am Objektiv dieser Kamera benötigt. (Zum Anbringen des 30,5-mm-Adapterrings muß die mitgelieferte Gegenlichtblende vom Objektiv entfernt werden.)

<Contax 30,5-mm-Filter (Aufschraubtyp)>

In fünf Ausführungen lieferbar: P (Objektivschutz), 1A, L39 (UV), A2 (81B) und B2 (82A).

<Contax Tvs Metall-Gegenlichtblende>

Für kombinierten Gebrauch mit einem 30,5-mm-Filter geeignet; Befestigung über 30,5-mm-Aufschraubring.

<Contax Tvs Metalldeckel K-34 (Stecktyp)>

Wird auf die Contax Tvs Metall-Gegenlichtblende gesetzt.

<Objektivdeckel K-31>

Wird auf einem Contax 30,5-mm-Filter angebracht.

<Contax Tix Semihard Case CC-67>

This is a quick-draw semi-hard case which can hold the Tix body together with an attached Tix 30.5mm ring, 30.5mm filter, Tvs metal hood, and metal cap K-34.

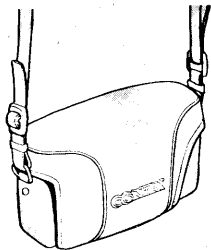

<Contax Tix Etui (halbhart) CC-67>

Dieses halbhartes Etui ermöglicht ein rasches Entnehmen der Kamera und kann das Kameragehäuse aufnehmen, während die folgenden Zubehörteile montiert sind: Contax Tix 30,5-mm-Zwischenring, 30,5-mm-Filter, Contax Tvs Metall-Gegenlichtblende und Metalldeckel K-34.

Camera Care

- Fingerprints and dirt on the lens and other areas can affect the accuracy of the camera. If the camera is soiled, wipe off gently clean the surfaces with a soft lens cleaning tissue moistened with lens-cleaning solution. Remove dust off by using with a blower brush.
- Use a soft cloth to clean the camera body. Never use organic solvents such as thinner or benzene.
- Wipe the camera clean after use at the seaside or in dusty areas.
Salt air will have a corrosive effect on the camera; sand and dust will be harmful to the camera mechanism.
- The lens may cloud if the camera is suddenly brought into a warm room from cold outdoor temperatures. Although this cloud will eventually disappear, avoid as much as possible exposing the equipment to sudden temperature changes.
- This camera includes dangerous high voltage circuits. In case of malfunction, never attempt to disassemble the camera by yourself.
- When using the camera for important occasions such as trips abroad or weddings, ensure operation beforehand or take test photographs to confirm proper operation. We also suggest bringing along a spare battery.
- This camera is a precision instrument. Do not drop it or expose it to intense shock.
- When using the camera in cold areas, store it inside clothing when not in use, remove it only to take pictures. Battery performance will be temporarily reduced when temperatures drop to near 0 degrees Centigrade to the point that the camera will not operate. The function of battery exposed to low temperature will be restored when the battery is returned to normal temperature.

<Camera Storage>

- Keep the camera away from heat moisture and dust and store it in an airy place. Do not store it in a wardrobe drawer containing moth balls or in a laboratory handling chemicals.

- Do not leave the camera and film for a long time in a hot place (on an ocean beach in summer, in a closed car under direct sunlight, etc.) as the camera, film and battery may be adversely affected.

<Battery Precautions>

- Battery performance will be reduced temporarily in low temperatures. If you are shooting in cold weather, keep the camera warm inside your jacket and take it out only when needed. Battery performance reduced by cold temperature will return to normal under normal temperature conditions.
- Poor contact may result if battery poles are soiled with sweat or grease. Wipe both poles clean before loading the battery.
- Bring spare battery with you, if you are going on a long trip.
- Do not throw used battery into a fire and do not charge, short, disassemble or heat them because it is dangerous.
- The camera will not function if the battery is not properly loaded.

<If the Camera Fails to Operate>

Under rare conditions, the camera may fail to operate when exposed to strong static electric fields. In such cases, turn off the main switch, remove the battery and wait until the display panel disappears, then return the battery to the battery compartment. Don't forget to reset the time and date, and any recording data selected.

<Precautions Regarding Handling of Film Cartridges>

The Advanced Photo System film cartridges record exposure and other information in the form of magnetic data. As a result, film cartridges should not be placed near magnets or exposed to machines generating strong magnetic fields (television sets, speakers, etc.), since the recorded magnetic data may be corrupted, thus impairing the unique features of the Advanced Photo System.

Specifications

Type: IX240 fully-automatic compact AF camera

Film Used: Leaderless thrust cartridge

Picture Size: 16.7 x 30.2 mm, with selectable print aspect ratio (C, H, P types)

Lens: Carl Zeiss T* Sonnar 28mm F2.8 (6 elements in 4 groups)

Shutter: Double between-type lens shutter

Shutter Speeds: 15 seconds - 1/1000 sec (maximum 1/500 sec at full-open aperture)

Lens Aperture: F2.8 - F16

Focusing Distance: 0.35m - ∞

Exposure Control: Program AE, Aperture-priority AE

Metering Range (at ISO 100): EV 0 to EV 18

Metering Method: External metering method

Exposure Compensation:

Single frame compensation: +1.5 EV;

Continuous compensation: +2.0 EV to -2.0 EV (in 1/3 steps)

Film Speeds: Automatic sensing (ISO 25 to ISO 10000, in 1/3 steps)

Focusing Method: External passive type, switchable between Multi-AF and "Spot" AF modes (with focus-lock function).

Viewfinder: Reverse Galileo-type, exterior illuminated bright-frame viewfinder, with automatic LED illumination under low-light conditions.

Viewfinder magnification: 0.5x

Print coverage field of view: 85%

Viewfinder display: focusing frame, close-range parallax correction frame, picture area frame (switchable in accordance with selected C, H, P aspect-ratio), focus indicator, exposure compensation indicator, flash indicator, program display.

Display Panel: Flash mode indicator (Auto-Flash Mode, Red-Eye Reduction Auto-Flash Mode, Flash-In Mode, Flash-Off Mode, Landscape Mode); Exposure data recording indicator; title recording indicator, "Spot" AF indicator; Exposure compensation value, Title number, Language number, Date, Shutter

speed; Date indicator; Battery warning indicator, Exposure counter, Cartridge indicator.

Film Loading: Drop-in loading

Film Transport: Automatic winding

Film Rewinding: Auto-return, auto-stop, with manual mid-roll rewind capability.

Exposure Counter: LCD display, decrementing type (displays number of remaining frames)

Self-Timer: Electronic type with ten-second operating time (LED flashes during operation)

Flash Unit: Internal fixed flash with flashmatic and guide-number control

Flash distance range: ISO 100: 0.35~2.1 m

ISO 200: 0.35~3.0 m

ISO 400: 0.35~4.3 m

Recycling time approximately 3 seconds (at room temperature, with new battery, in accordance with Contax testing standards)

Magnetic Data Recording:

Basic information:

Date, time, CHP print-aspect-ratio

PQI information:

Exposure information: F-stop, shutter speed, exposure compensation value

Title Recording:

Selectable from total of 54 titles (9 title items in 6 languages).

Printing Function:

- ① Dual-side printing of date, time data
- ② Rear-side printing of exposure data or selected title.

Battery: 3V Lithium battery (CR2): 1

Battery capacity: About 20 25-exposure rolls, when shooting approximately 50% flash exposures (at room temperature, with new battery, in accordance with Contax testing standards).

Dimensions: 100.5 (W) x 60.5 (H) x 33 (D) mm

Weight: 225 g

* Specifications and design are subject to change without notice.